

## T834C, T8034C Heating/Cooling Thermostats

### PRODUCT DATA



### FEATURES

- Integral switches control Heat-Off-Cool System switching and Auto-On or On-Auto Fan switching.
- Standard heating-cooling, single-stage heat pump, and electric heat models available.
- Coiled bimetal operates silent, dust-free spdt mercury switch.
- T834C models have vented cover to provide better air flow for temperature sensing.
- Adjustable heat anticipator and fixed cool anticipator on all models.
- T834C models mount directly on wall or on a *vertical* outlet box.
- T8034C models mount directly on wall or on a *horizontal* outlet box.
- SUPER TRADELINE® T8034C includes horizontal wallplate for covering marks from old thermostat.
- Accessory mounting plate assembly allows mounting T834C on horizontal outlet box or T8034C on vertical outlet box.

### APPLICATION

T834C and T8034C Thermostats provide low voltage control of single-stage heating, cooling or heating-cooling systems.

### Contents

Application .....	1
Features .....	1
Specifications .....	2
Ordering Information .....	2
Installation .....	3
Settings and Adjustments.....	7
Checkout .....	8



## SPECIFICATIONS

The specifications given in this publication do not include normal manufacturing tolerances. Therefore, this unit may not exactly match the listed specifications. Also, this product is tested and calibrated under closely controlled conditions, and some minor differences in performance can be expected if those conditions are changed.

## SUPER TRADELINE®/TRADELINE® MODELS

SUPER TRADELINE®/TRADELINE® models are selected and packaged for ease of handling, ease of stocking, and maximum replacement value. SUPER TRADELINE®/TRADELINE® models specifications are the same as those of standard models except as follows:

### **SUPERTRADELINE® Models:**

T843C Heating-Cooling Thermostat for use in gas-fired, oil-fired, or central electric heat and standard cooling systems; mounts vertically; adjustable heat anticipator—0.18 to 1.0A.

T8034C Heating-Cooling Thermostat for use in gas-fired, oil-fired or central electric heat and standard cooling systems; mounts horizontally; adjustable heat anticipator—0.18 to 1.0A.

### **Additional SUPERTRADELINE® Features:**

- Fan can be controlled from thermostat or plenum switch.
- Wallplate for covering marks from old thermostat (T8034C only).

### **TRADELINE® Models:**

T843C Heating-Cooling Thermostat for use in single-stage heat pump, electric furnace and standard heating-cooling systems; mounts vertically; adjustable heat anticipator—0.18 to 1.0A. Model available with °C scaleplate.

T8034C Heating-Cooling Thermostat for use in standard heating-cooling systems; mounts horizontally; adjustable heat anticipator—0.18 to 1.0A. Model available with °C scaleplate and isolated heat-cool circuits for systems with separate heating and cooling transformers.

## STANDARD MODELS

### **Standard Models:**

T834C Heating-Cooling Thermostat for use in standard heating-cooling systems. Single-stage heat pump, electric heat and dual fuel models also available. Mounts vertically. Provides Heat-Off-Cool System switching and Auto-On or On-Auto Fan switching (specify when ordering).

T8034C Heating-Cooling Thermostat for use in standard heating-cooling systems; mounts horizontally. Provides Heat-Off-Cool System switching and On-Auto Fan switching. Canadian model available with °C scaleplate, and isolated heat-cool circuits for systems with separate heating and cooling transformers.

### **Electrical Ratings:**

Heating: 0.18 to 1.0A at 30 Vac maximum; (0.3 to 1.2A optional).

Cooling: 1.5A running, 7.5A inrush at 25 Vac.

Heat Anticipator: Adjustable 0.18 to 1.0A, 0.3 to 1.2A (specify when ordering).

Cooling Anticipator: Fixed, 24 to 30 Vac.

### **Switching:**

Heating: Spdt mercury switch makes R to W on temperature fall.

Cooling Thermostats: Spdt mercury switch makes R to Y on temperature rise.

### **Temperature Setting Range (Specify When Ordering):**

55° F to 95° F (13°C to 35 °C).

10°C to 30°C (50°F to 86°F).

**Dimensions:** See Fig. 1 and 2.

**Mounting Means:** Two screws through base to wall or 2 x 4 in. outlet box. T834 fits on vertical outlet box; T8034 fits on horizontal outlet box.

## ORDERING INFORMATION

When purchasing replacement and modernization products from your TRADELINE® wholesaler or distributor, refer to the TRADELINE® Catalog or price sheets for complete ordering number.

If you have additional questions, need further information, or would like to comment on our products or services, please write or phone:

1. Your local Honeywell Automation and Control Products Sales Office (check white pages of your phone directory).
2. Honeywell Customer Care  
1885 Douglas Drive North  
Minneapolis, Minnesota 55422-4386

In Canada—Honeywell Limited/Honeywell Limitée, 35 Dynamic Drive, Scarborough, Ontario M1V 4Z9.

International Sales and Service Offices in all principal cities of the world. Manufacturing in Australia, Canada, Finland, France, Germany, Japan, Mexico, Netherlands, Spain, Taiwan, United Kingdom, U.S.A.

**Accessories:**

- 200581 Horizontal Wallplate for T8034C; covers mounting marks from old thermostat.
- 193121A Mounting Plate Assembly for T834 or T8034C; includes mounting plate, adapter ring, mounting screws and instructions. Adapter ring allows use of T34 or T8034C on vertical box. Mounting plate is 6-7/8 in. x 4-3/4 in. (154 mm x 106 mm) to cover wall marks where larger plate is needed.
- 104994A Calibration Wrench.
- 209649A Universal Cover Plate (Taupe) is 7-3/4 in. x 5-3/4 in. (288 mm x 146 mm) to cover wall marks from old thermostat.
- 209650A Universal Cover Plate (White) is 7-3/8 in. x 5-3/4 in. (288 mm x 146 mm) to cover wallmarks from old thermostat.

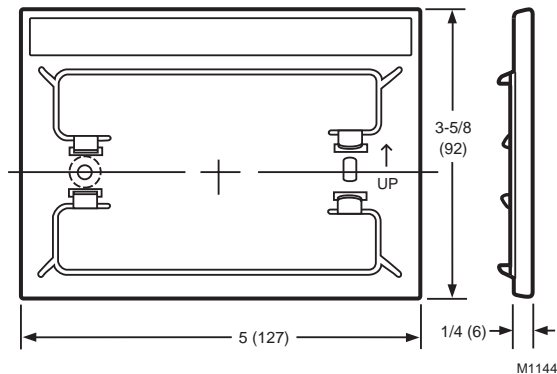

**Fig. 2. 200581 Horizontal Wallplate approximate dimensions in in. (mm). (For use with T8034C Thermostat.)**

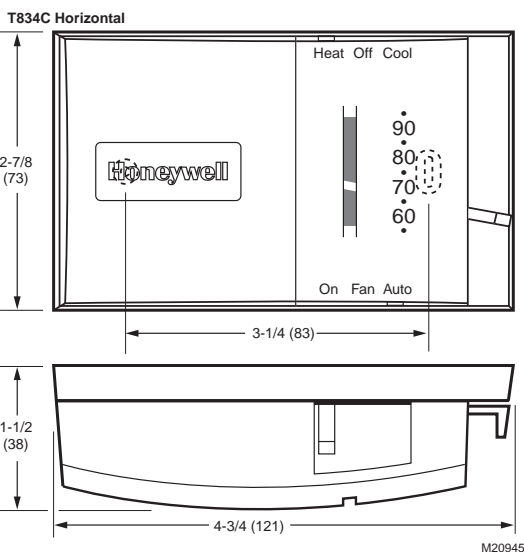
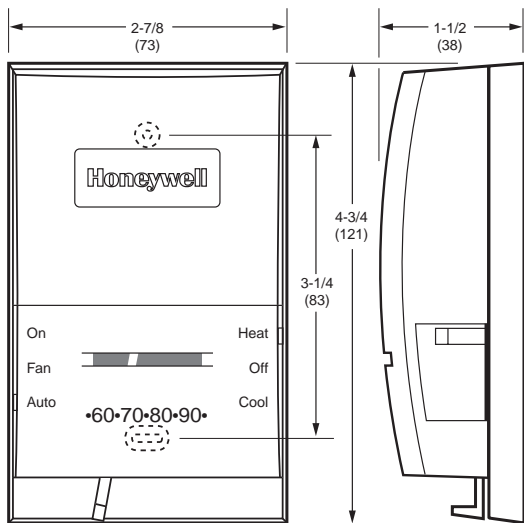

**Fig. 1. T834C Thermostat approximate dimensions in in. (mm). (T8034C Thermostat has same dimensions except mounting is horizontally.)**

**INSTALLATION**

**When Installing this Product...**

1. Read these instructions carefully. Failure to follow them could damage the product or cause a hazardous condition.
2. Check the ratings given in the instructions and on the product to make sure the product is suitable for your application.
3. Installer must be a trained, experienced service technician.
4. After installation is complete, check out product operation as provided in these instructions.

**! CAUTION**

**Electrical Hazard.**  
**Can cause personal electrical shock or equipment damage.**  
 Disconnect power supply before beginning installation.

**Location**

Locate the thermostat about 5 ft (1.5m) above the floor in an area with good air circulation at average temperature. do not mount the thermostat where it may be affected by:

- drafts or dead spots behind doors or in corners.
- hot or cold air from ducts.
- radiant heat from the sun, fireplaces, or appliances.
- concealed pipes and chimneys.
- unheated (uncooled) areas behind the thermostat, such as an outside wall.

**Mounting and Wiring**

Disconnect power supply before beginning installation.

**IMPORTANT**

*All wiring must comply with local codes and ordinances.*

## T834C

The T834C can be mounted directly on a wall or vertical outlet box:

- Use the 193121A Mounting Plate Assembly (ordered separately) to mount thermostat on horizontal outlet box or to cover marks from an old thermostat.
- If mounting plate assembly is used, review instructions provided with assembly before wiring and mounting thermostat.
  1. In replacement applications, check existing thermostat wires for cracked or frayed insulation. Replace any wires in poor condition.

**NOTE:** If wire is plastered into the wall, make a hole next to the wires and loosen them so they can be pushed back into the wall later.

2. In new installations, run wiring, if necessary, to the thermostat location.
3. Connect the wires to the terminals on back of thermostat. See Fig. 5-9 for internal schematics and typical hookup diagrams. For systems requiring thermostat control of fan operation in heat (some electric heat applications), jumper terminals 1 and 2. See Fig. 3.
4. Remove thermostat cover by pulling outward from indentation on right or left side of cover until it snaps free of thermostat base. Carefully remove and discard foam plastic shipping insert protecting switch and bimetal assembly during shipping.
5. Set the adjustable heat anticipator indicator to match the current draw of the primary heating control (see Heat Anticipator Setting).
6. Push excess wire back through the hole and plug any opening with insulation to prevent drafts that can affect thermostat performance.
7. Loosely fasten the thermostat and mounting plate, if used, to the wall or outlet box with a screw through the top mounting hole. Adjust thermostat so it is approximately level and start the second screw through the bottom mounting hole. Do not tighten.
8. Level the thermostat exactly using a level device. Tighten the mounting screws.

### IMPORTANT

*This thermostat is calibrated at the factory, mounted at true level. Any inaccuracy in leveling during the mounting causes control point deviation.*

9. Replace thermostat cover.

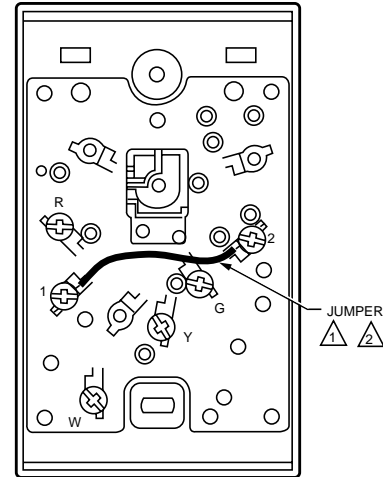

▲ IN ELECTRIC HEAT AND HEAT PUMP APPLICATIONS, JUMPER TERMINALS 1 AND 2 FOR AUTOMATIC FAN CONTROL IN HEATING AND COOLING.

▲ IN GAS-AND OIL-FIRED APPLICATIONS, JUMPER TERMINALS 1 AND Y FOR AUTOMATIC FAN CONTROL IN COOLING.

M8675

**Fig. 3. Jumpering terminals 1 and 2 to control fan operation from thermostat during heating (electric heat application).**

## T8034C

The T8034C can be mounted directly on a wall or horizontal outlet box:

- Use the 200581 Horizontal Wallplate to cover mounting marks from an old thermostat or use 193121A Mounting Plate Assembly to mount thermostat on vertical outlet box or to cover marks from an old thermostat where a larger plate is needed. (The SUPERTRADELINE T8034C includes the 200581 Horizontal Wallplate. For other T8034C models, horizontal wallplate or mounting plate assembly must be ordered separately.)
  - Using 200581 Horizontal Wallplate: Align thermostat and wallplate (see Fig. 4) and press firmly together until wallplate snaps in place; then wire and mount the thermostat.
  - Using 193121A Mounting Plate Assembly: Review instructions provided with assembly before wiring and mounting thermostat.

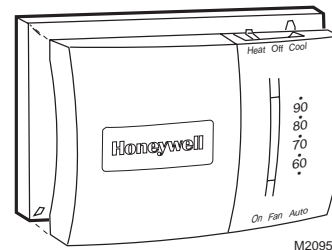

M20951

**Fig. 4. Mounting SUPERTRADELINE T8034C on wallplate.**

To wire and mount thermostat.

1. In replacement applications, check existing thermostat wires for cracked or frayed insulation. Replace any wires in poor condition.

NOTE: If wire is plastered into the wall, make a hole next to the wires and loosen them so they can be pushed back into the wall later.

2. In new installations, run wiring, if necessary, to the thermostat location.
3. Connect the wires to the terminals on back of thermostat. See Fig. 5-9 for internal schematics and typical hookup diagrams. For systems requiring thermostat control of fan operation in heat (some electric heat applications), jumper terminals 1 and 2. See Fig. 3.
4. Remove thermostat cover by pulling outward on right or left edge of cover until it snaps free of thermostat base. Carefully remove and discard foam plastic shipping insert protecting switch and bimetal assembly during shipping.

5. Set the adjustable heat anticipator indicator to match the current draw of the primary heating control (see Heat Anticipator Setting).
6. Push excess wire back through the hole and plug any opening with insulation to prevent drafts that can affect thermostat performance.
7. Loosely fasten the thermostat and wallplate, if applicable, to the wall or outlet box with a screw through the left mounting hole. Adjust thermostat so it is approximately level and start the second screw through the right mounting hole. Do not tighten.
8. Level the thermostat exactly using a level device. Tighten the mounting screws.

**IMPORTANT**

*This thermostat is calibrated at the factory, mounted at true level. Any inaccuracy in leveling during the mounting causes control point deviation.*

9. Replace thermostat cover.

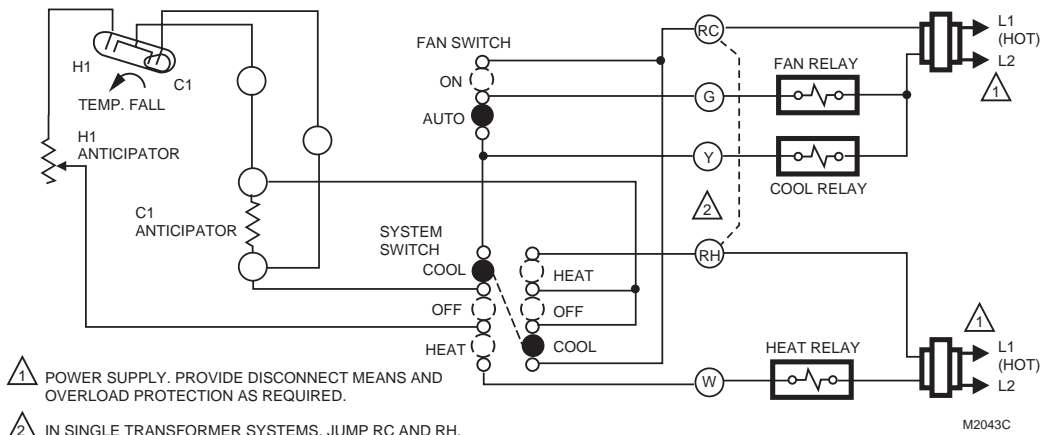

**Fig. 5. Internal schematic and typical hookup diagram for standard heating-cooling systems.**

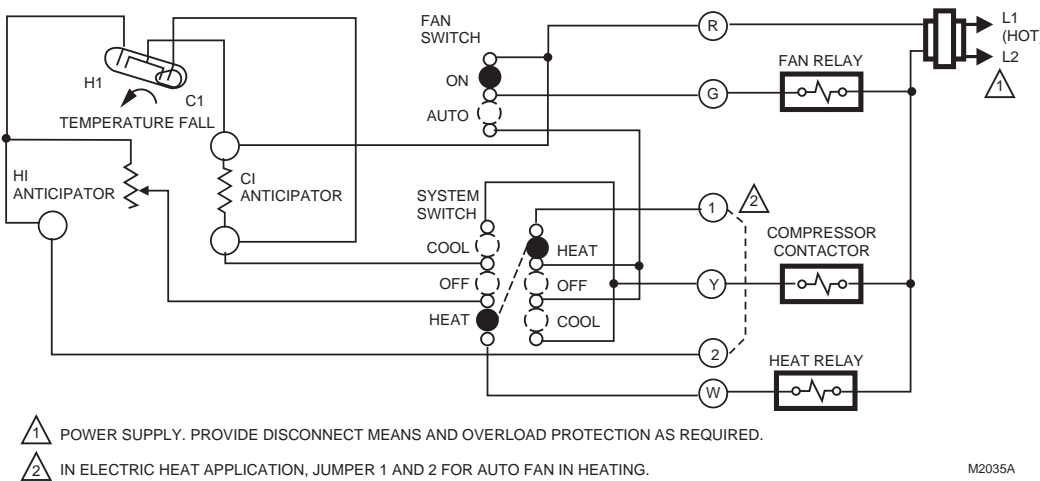

**Fig. 6. Internal schematic and typical hookup diagram for gas-fired, oil-fired, or central electric heat applications. (Jumper terminals 1 and 2 to control fan operation from thermostat during heating when using thermostat in electric heat applications.)**

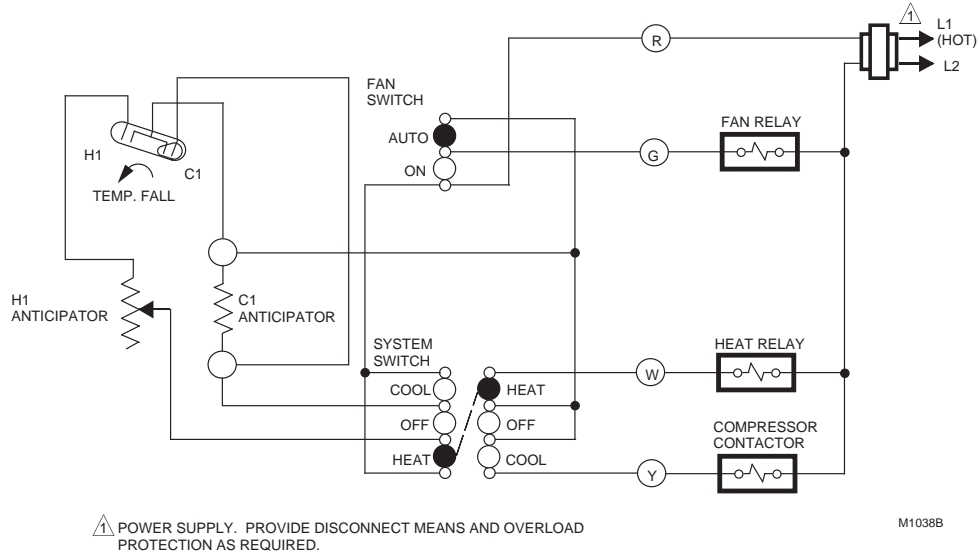

**Fig. 7. Internal schematic and typical hookup diagram for electric heat systems.**

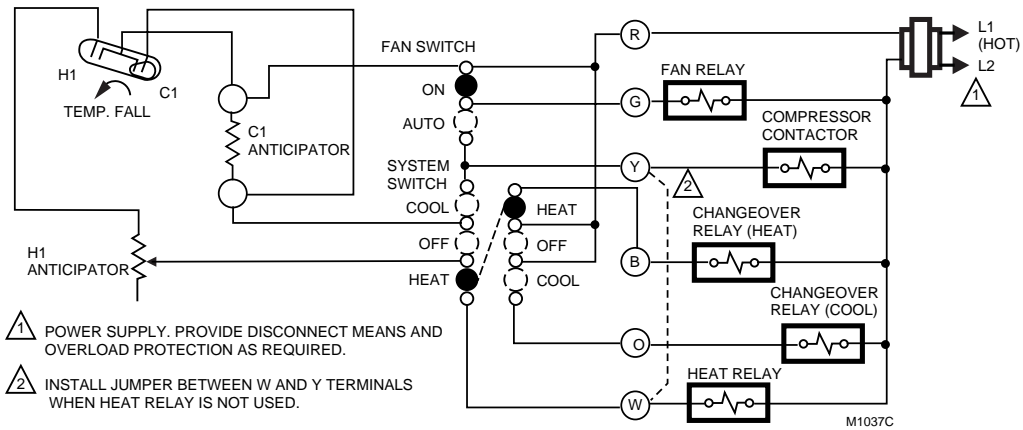

**Fig. 8. Internal schematic and typical hookup diagram for single-stage heat pump systems.**

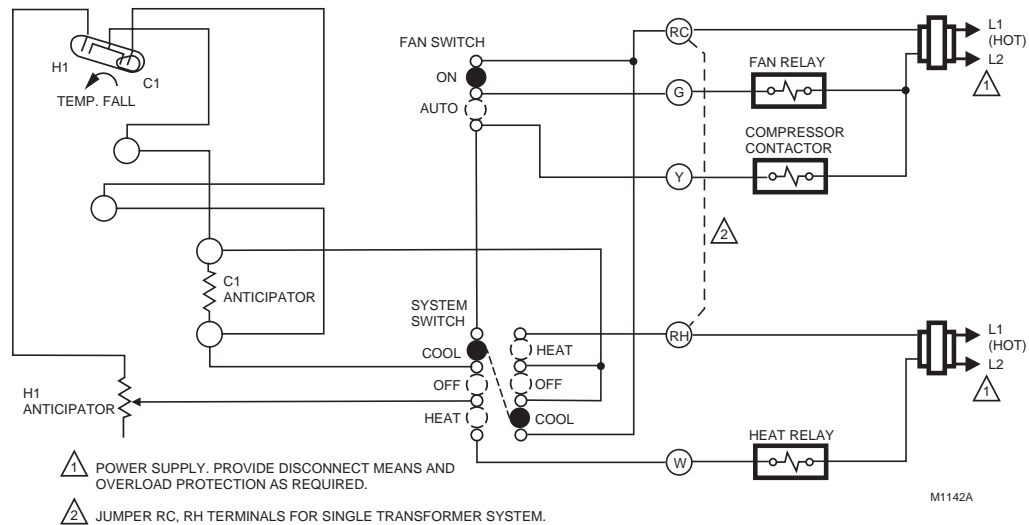

Fig. 9. Internal schematic/typical hookup diagram for systems with separate heating and cooling transformers (Canadian model only.)

## SETTINGS AND ADJUSTMENTS

### Temperature Setting

Move the temperature setting lever to the desired control point on the temperature scale. The same lever controls the temperature setting of both heating and cooling.

### Fan and System Switching

The T834C and T8034C feature System and Fan switches for control of the heating-cooling and fan systems.

The System switch controls system operation as follows:

Heat: Heating system only operates.

Off: Both heating and cooling control systems are disconnected.

Cool: Cooling system only operates.

The Fan switch controls fan operation as follows:

Auto: For gas-fired or oil-fired systems, the fan operates in response to the plenum fan control in heating; fan operates in response to the thermostat in cooling. For some heat pump and electric heat systems, the fan operates in response to the thermostat in both heating and cooling.

On: The fan operates continuously.

To switch positions, use thumb and index finger to slide lever to desired position. Switch lever must stop directly over desired function indicator mark for correct circuit operation.

### Heat Anticipator Setting

#### IMPORTANT

- This thermostat has an adjustable heat anticipator and operates correctly only if the anticipator is adjusted to match the current draw of the primary control.
- Use this thermostat only on systems with current draws that fall within the range of the heat anticipator. Do not use this device on Powerpile (millivolt) systems.

1. A current rating is usually stamped in the nameplate of the primary control. Set the adjustable heat anticipator indicator to match the value given on the nameplate.
2. If the current rating is not available, proceed as follows to determine the rating:
  - a. Turn off the power.
  - b. Wire thermostat, except connection to W terminal, but do not mount it on the wall.
  - c. Connect ammeter between W wire and W terminal on thermostat.
  - d. Prepare system for operation.
  - e. Turn on power.
  - f. Turn System switch to Heat.
  - g. Increase thermostat setpoint, as necessary, to start system operating.
  - h. With system operating through ammeter, wait one minute, then read ammeter.
  - i. Turn System switch to Off and turn off power.
  - j. Adjust heat anticipator to match reading on ammeter.
  - k. Disconnect ammeter, reconnect W wire, and mount thermostat. Continue with system checkout.

NOTE: The heat anticipator may require further adjustment for best performance. To lengthen burner-on time, move indicator in direction of longer arrows but not more than a half-scale marking at a time. To shorten burner-on time, move indicator in opposite direction.

## CHECKOUT

### ! CAUTION

#### Checkout Method Hazard.

#### Can damage thermostat heat anticipator.

Avoid checking thermostat operation by shorting across system control terminals.

#### IMPORTANT

— To ensure accurate temperature control, do not touch or breathe on bimetal of thermometer.

## Heating

1. Set system switch to Heat and Fan switch to Auto.
2. Move temperature setting lever about 10°F (6°C) above room temperature.
  - Gas or oil -fired systems: Heating starts immediately. Fan starts after short delay.
  - Heat pump and some central electric heating systems: Heating and fan start.
3. Move temperature setting lever about 10°F (6°C) below room temperature.
  - Gas or oil-fired systems: Heating shuts off immediately. Fan shuts off after a short delay.
  - Heat pump and some electric heat systems: Heating and fan shut off.

## Cooling

### ! CAUTION

#### Equipment Damage Hazard.

#### Can short-cycle air conditioner compressor.

Install minimum-off timer to provide five-minute time delay to prevent operating compressor for five minutes after thermostat turns off compressor or for five minutes after system receives power.

Avoid operating thermostat in cooling applications when outdoor temperature is below 50°F (6°C). See air conditioner manufacturer recommendations.

1. To prevent compressor short cycling, install a minimum off-timer to provide a five-minute time delay. (The time delay will not activate the compressor for five minutes after the thermostat turns off the compressor or for five minutes after the system receives power.)
2. With System switch set to Cool and Fan switch set to Auto, move the temperature setting lever about 10°F (6°C) below room temperature. Cooling and fan should start immediately.
3. Move temperature setting lever about 10°F (6°C) above room temperature. Cooling and fan should shut off.

## Fan

1. With System switch set to Off and Fan switch set to On, the fan runs continuously.
2. Move Fan switch to Auto. In gas-fired or oil-fired systems, fan operation is controlled by thermostat in cooling and by plenum fan control in heating. In heat pump and some central electric heat systems, fan operation is controlled by the thermostat in both heating and cooling.

## Recalibration

These thermostats are calibrated at the factory and should not require recalibration. If thermostat seems out adjustment, first check for accurate levelling. To check calibration:

1. Move temperature setting lever to low end of temperature scale. (**System switch must be placed to Off. Wait at least five minutes.**)
2. Remove thermostat cover. Move temperature setting lever until switch just makes contact. (The mercury in the switch will drop to the contact end of the tube.)
3. Replace the thermostat cover and wait five minutes for the cover and the thermostat to lose the heat it has gained from your hands. (If the thermometer pointer and the temperature lever indicator read approximately the same, no recalibration is needed.)
4. If recalibration appears necessary, use this procedure:
  - a. Place temperature setting lever at same setting as thermometer.
  - b. Remove the thermostat cover.
  - c. Insert 104994A Calibration Wrench (ordered separately) onto hex nut under coil. See Fig. 10. Holding setting lever so it does not move, turn wrench clockwise until mercury rolls to right end of tube.
  - d. Remove wrench and replace thermostat cover.
  - e. Move temperature setting lever to low setting. Wait at least five minutes for temperature to stabilize.
  - f. Slowly move the temperature setting lever until it reads the same as the thermometer.
  - g. Remove cover. Holding temperature setting lever so it does not move, reinsert the wrench and carefully turn the wrench counterclockwise until the mercury just rolls to the left end of the tube, *but no farther*.
  - h. Recheck calibration by setting thermostat System switch for the desired operation.
  - i. Replace the cover.

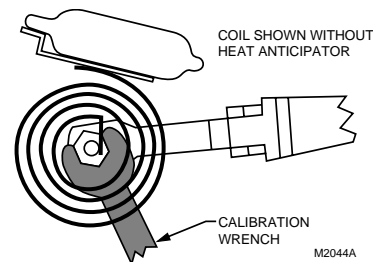

Fig. 10. Recalibrating thermostat.

# Honeywell

#### Automation and Control Solutions

Honeywell International Inc.	Honeywell Limited-Honeywell Limitée
1985 Douglas Drive North	35 Dynamic Drive
Golden Valley, MN 55422	Scarborough, Ontario
	M1V 4Z9

